

TECHNICAL INFORMATION SHEET: NEMOTO NAP-50A & NAP-55A Catalytic Flammable Gas Sensors



Features:

- Low cost design for Domestic Gas Detectors
- Linear output to 50%LEL (Natural Gas)
- Small size
- Long life

General Description:

The Nemoto NAP-50A and NAP55A are catalytic (pellistor) type flammable gas sensors supplied as matched pairs of catalytic elements mounted on a single header enclosed in a plastic housing and protected by a metal mesh. Designed as a gas sensor for use in **Domestic (Residential) Gas Detectors**, the sensor detects and measures the presence of flammable gases and vapours in air, in the range 0-50% of the Lower Explosive Limit (LEL) of the gas or vapour being measured.

The highly advanced and efficient production techniques developed by Nemoto means that the cost of technically superior pellistor technology, usually reserved for Industrial Applications, is now appropriate low enough for them to be used for domestic gas detectors, which have hitherto

tended to use less expensive, but less stable and less selective semiconductor type gas sensors.

The two variants of this sensor (NAP-50A and NAP-55A) are very similar in performance: The NAP50A is a slightly modified version of the original NAP55A sensor, to reduce the effect of potential cross sensitive gases likely to be encountered in domestic premises, particularly Ethanol, in compliance with the European standard for domestic gas detectors EN 50194.

The NAP-55A should therefore be used where maximum sensitivity to all flammable gases is required, whereas the NAP-50A should be selected if high sensitivity to natural gas or LPG only is required, and the lowest cross sensitivity to other flammable gases and vapours is desirable.

Specifications: (applies to both variants)

Recommended Voltage:	2.6V +/- 0.25V
Current Drawn:	170 +/- 10mA
Zero Offset:	0mV +/- 35mV
Output Sensitivity:	12-16mV @3000ppm CH ₄
Range:	0-50% LEL
Repeatability:	+/- 0.5mV CH ₄
Maximum Long Term Drift:	
Expected Lifetime in the field:	>5 years*
Response Time (T ₉₀):	8 sec
Temperature Range:	-10°C to +50°C
Humidity:	0-95% RH, non-condensing

* measured as time for output to fall below 40% of original, in a typical domestic environment

Further Performance information and Test data on drift, poisoning, temperature performance, linearity etc will be available on the Characterisation Document NAP50-55CD.doc

Nemoto has a policy of continuous development and improvement of its products. As such the specification for the device outlined in the data sheet may be changed without notice

Sensor Dimensions and Circuitry:

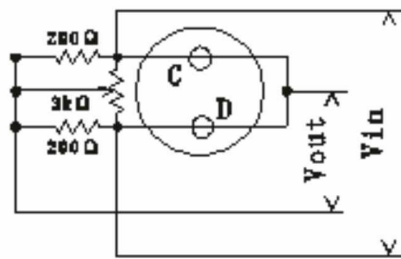
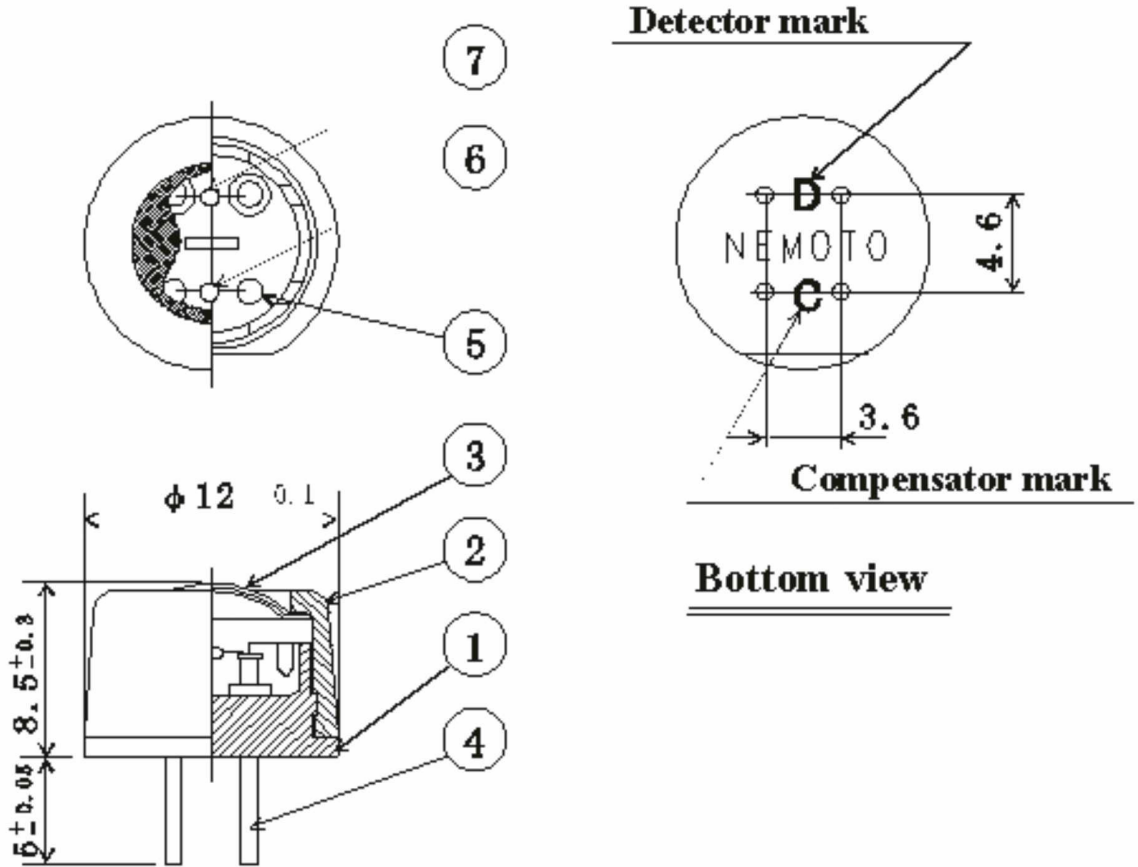

Measuring Circuit

No.	Parts names	Material	Remarks
1	Mount	Nylon 66	Glass 20% contained
2	Cap	Nylon 66	Glass 20% contained
3	Mesh	SUS 316	#100, Double mesh
4	Pin	Pure Ni	φ 0.8
5	Coil	PPT	φ 30 μm
6	Compensator		Nemoto & Co
7	Detector		Nemoto & Co

ds-nap50-55.doc, issue 4, May 2008